

Day 4 course

VSAT installation and Maintenance

1- VSAT Installation

Sample Hardware list

The VSAT system consists of the following hardware:

- The Outdoor unit assembly
- The Indoor unit assembly

1- VSAT Installation

Sample Hardware list



The **outdoor** unit assembly consists of:

- 1.2 m antenna operating in the Ku band
- Standard L-band LNB for the receiving signal. The LNB converts the Ku band signal received from the satellite into an L band signal.
- Transmitter for the transmitting signal. The transmitter converts the L band signal transmitted from the VSAT into a Ku band signal.
- OMT (Orthomode Transducer) separates the transmit signal from the received signal, taking advantage of their different polarization and frequency.
- Two IFL cables connecting the indoor unit assembly with the outdoor unit assembly. The IFL (Inter-Facility Link) cabling carries the inbound and the outbound signals and the 24 VDC for the LNB.

1- VSAT Installation

Sample Hardware list

The indoor unit assembly consists of the Indoor Unit (IDU) which contains the following:

- The Modulator
- The Demodulator
- Two serial and one Ethernet port.

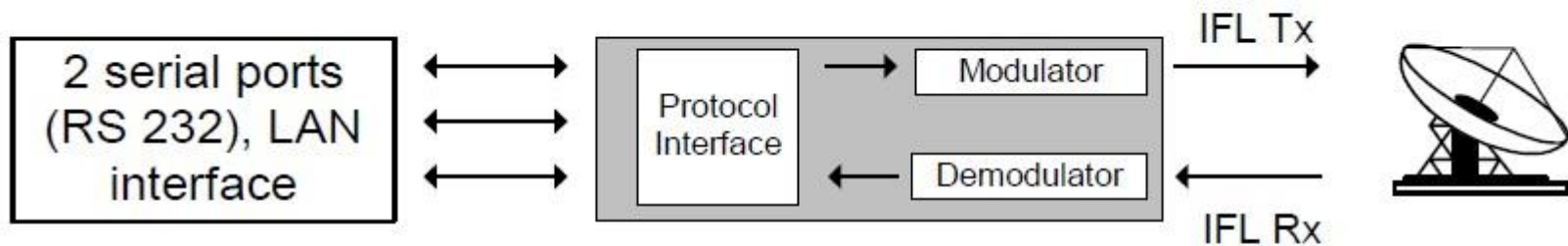

VSAT system architecture (block diagram)

1- VSAT Installation

General flow chart concerning VSAT installation

The actions that will follow the site survey until bringing the VSAT online are:

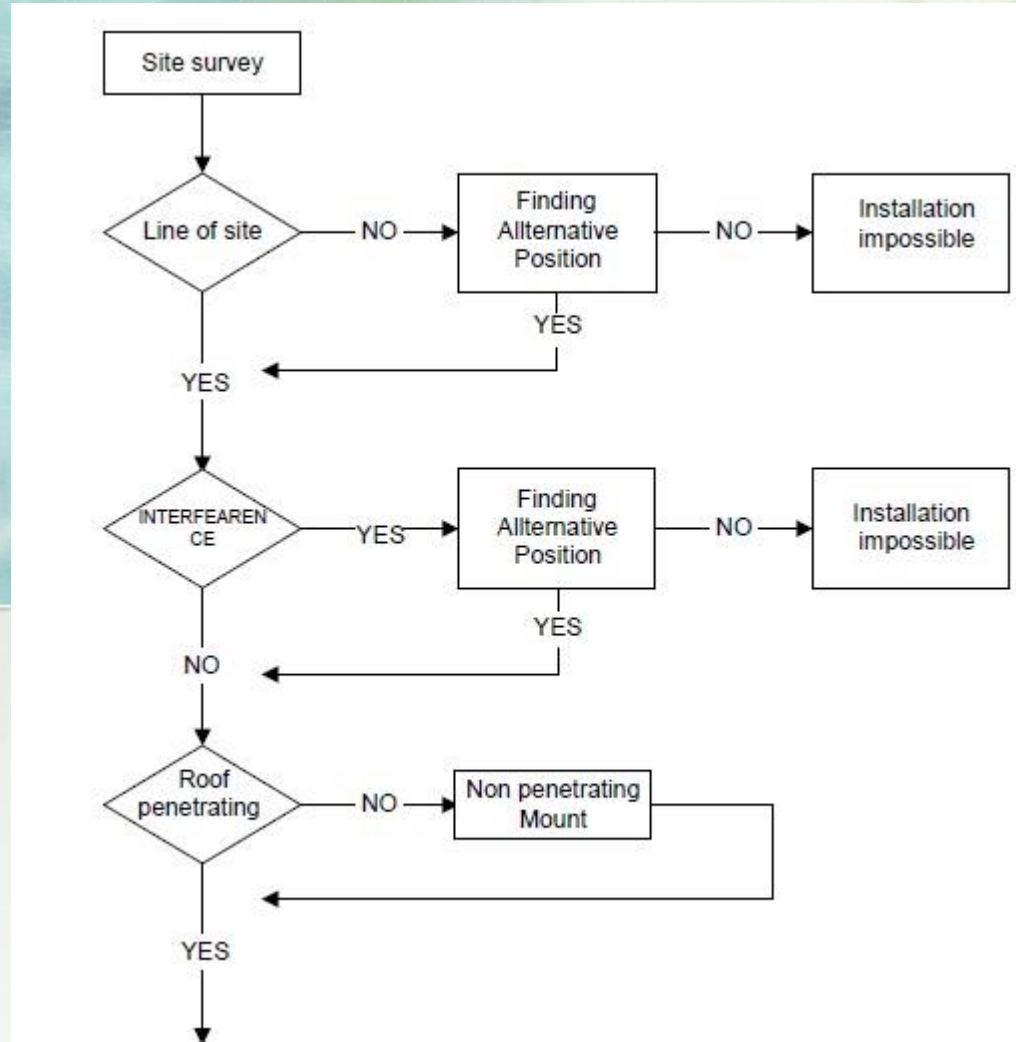

1- VSAT installation

General flow chart concerning VSAT installation

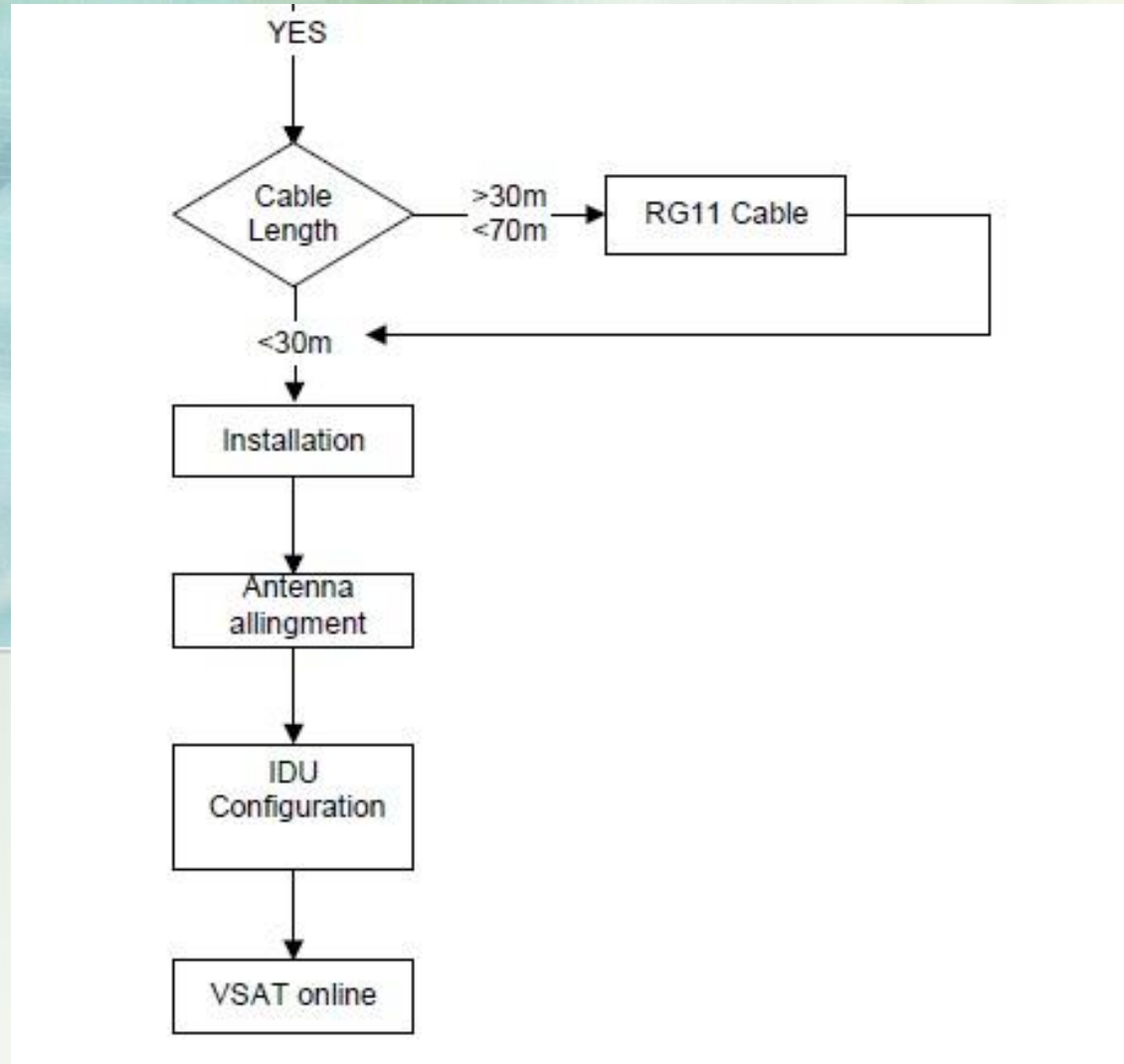

1- VSAT Installation

Site Survey

Before installation, a field operations engineer should visit the site at which the VSAT is to be installed. The engineer has to take care of the following:

- Absence of high-rise buildings, trees etc, which may block the signal path.
- Absence of interference by using a gun and a field meter.
- Existence of AC power during installation.
- Existence of a clear, unobstructed line of sight to the designated satellite
- Acquisition of the longitude and latitude using GPS.
- Existence of a LAN network near the IDU.
- Estimation of the maximum cable length.
- Free access to the roof of the building.

1- VSAT Installation Site Survey

Absence of high-rise buildings, trees etc, which may block the signal path.

If the elevation is between 30° and 60°
Imagine an arc ranging from 30 to 60 degrees above the horizon.

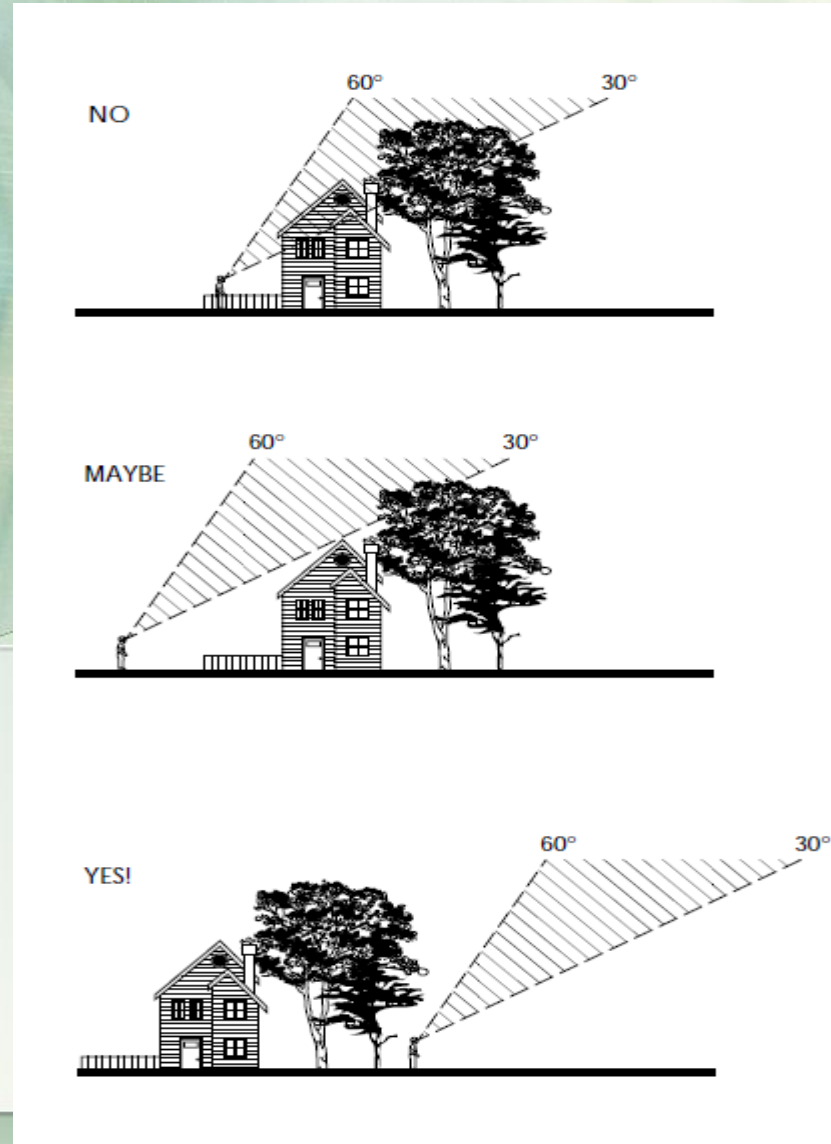

1- VSAT Installation

Site Survey

The **IDU** is designed for installation indoors. It may be placed on top of a bench or on a shelf in a rack. While placing the IDU the following requirements should be met:

- The IDU includes a fan for ventilation. To allow proper airflow and to guarantee safe operation of the VSAT equipment, make sure that:
 - The rear panel of the IDU is not covered.
 - The IDU is not placed in an unventilated enclosure.
 - At least 10 cm of space along the IDU sides are left for ventilation.
 - The maximum ambient temperature is 50 oC.
 - Place the IDU where it can be easily accessed by a technician during maintenance.
- Place the IDU away from electromagnetic field emitting devices.

1- VSAT Installation

Roof penetrating

- If penetrating the roof is allowed, secure the pole to the roof with penetrating large bolts. Apply silicon for additional rain protection.
- In case penetration of the roof is not possible, a non-penetrating mount should be used.

1- VSAT Installation

Typical VSAT Setup

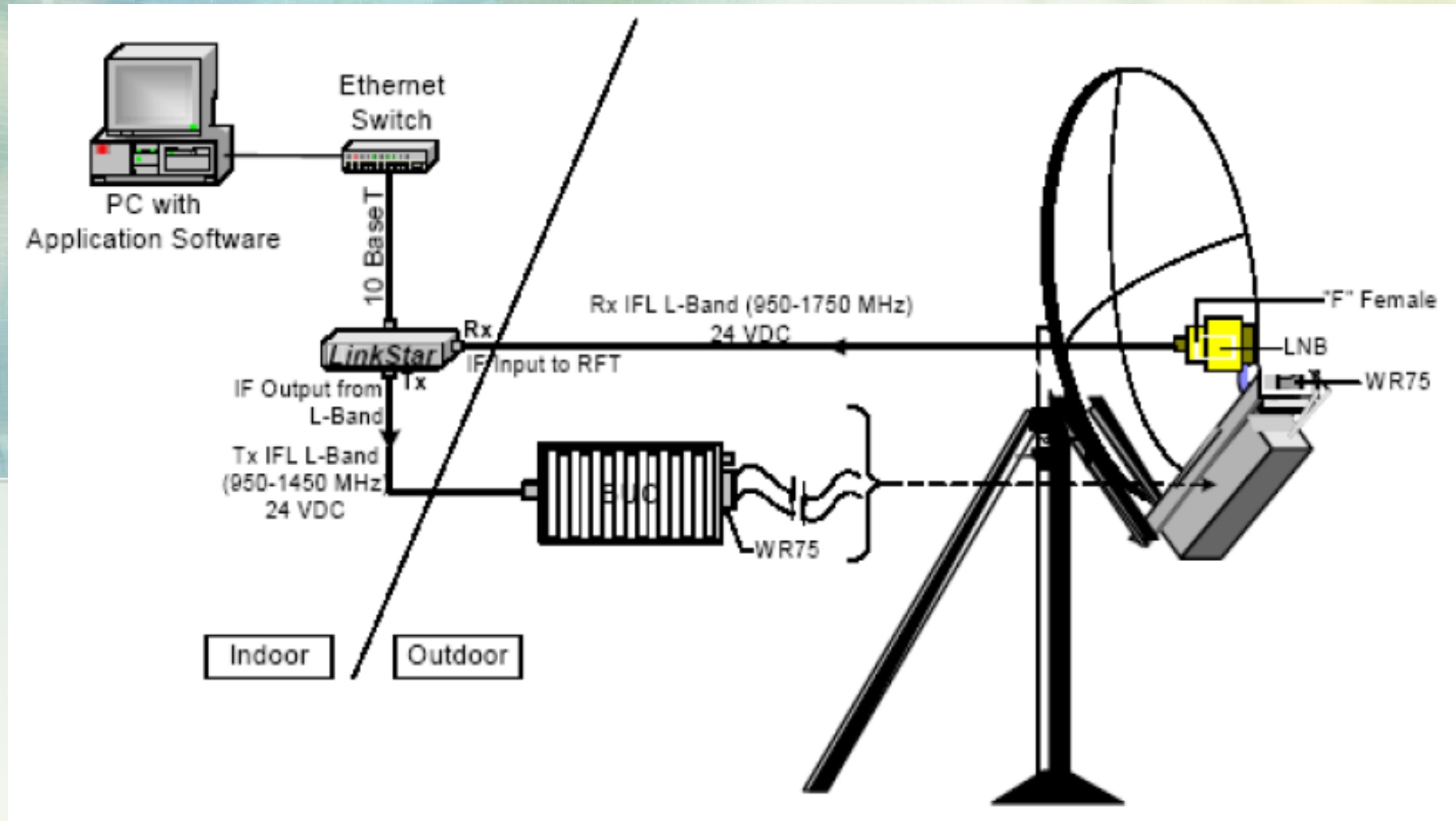

1- VSAT Installation

ODU assembly and installation

Install the AZ/EL cap on the ground pole by inserting the four plow bolts into the holes in the reflector face and insert the exposed portion of the bolts into the holes in the antenna mount flange. Tighten the clamp nuts so that the cap is held stationary on the pole.

After setting the antenna to the approximate azimuth and elevation angles, assemble and attach the ODU to the antenna as described in the following sections.

1- VSAT Installation

ODU assembly and installation

Attach the LNB and the transmitter to the OMT (Orthomode Transducer) after placing the “O”- Ring on its corresponding groove on them.

Verify that the wave-guide polarization is correct both in the LNB and the transmitter.

The correct polarization is set by rotating the outdoor electronics to the appropriate position (this *has to be done* through a phone call to the NOC).

The VSAT is designed to receive and transmit on opposite polarization.

1- VSAT Installation

ODU assembly and installation

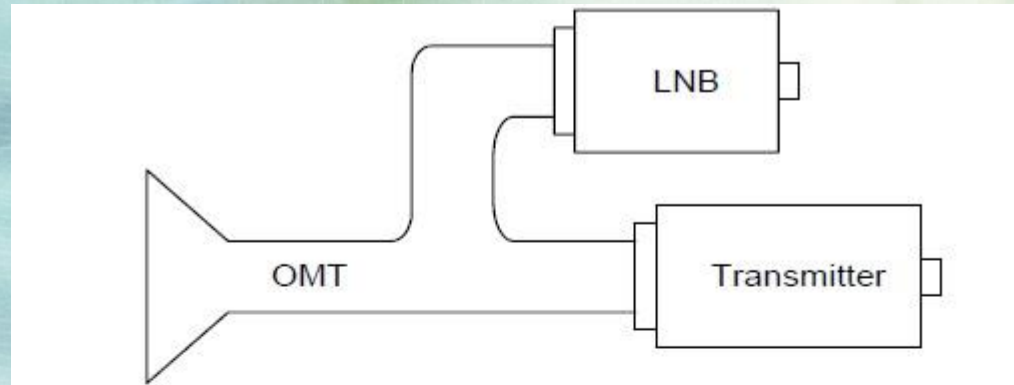

figure 1: LNB and Transmitter assembly

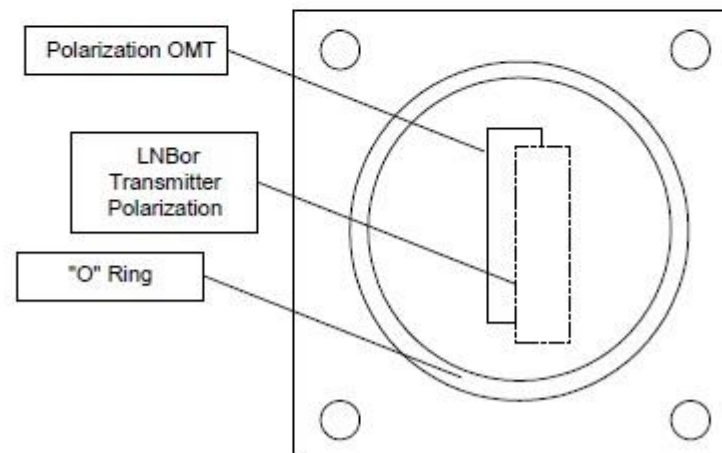

figure 2: correct wave guide polarization

1- VSAT Installation

ODU assembly and installation

Tighten the screws. Assemble the feed legs to the antenna. Assemble the feed mounting block to the feed support legs. Tighten the hardware securing side and the bottom feed legs to the feed support block and the reflector.

Place the ODU assembly on the antenna support arm. Tighten the nuts and finally connect the two coaxial cables to the LNB OUT port and the Transmitter IN port.

1- VSAT Installation

Antenna alignment

Point your dish to the satellite, if you have a spectrum analyzer, you can see your signal at for example 11597.408 MHz RF frequency, or 1597.408 MHz L-band frequency (the output of the VSAT is L-band) and try to maximize it by slowly turning the feeder to the left or right. Screwing the feeder back, will have to be done extremely cautiously (one screw at a time, just 1 turn until all screws are in place)

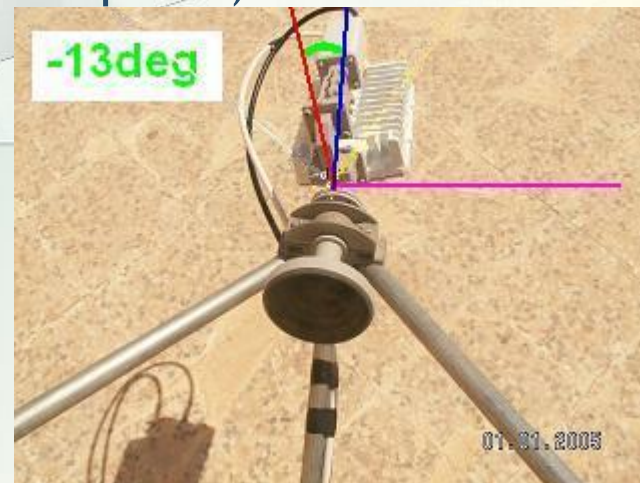

Horizontal polarization adjusted by -13 deg anticlockwise, while facing the satellite

1- VSAT Installation

Antenna alignment

Set the antenna to the approximate azimuth angle and elevation angles. The exact azimuth and elevation angles come out of the exact geographical longitude and latitude.

Channel Master antenna, for example, have 17 degrees offset. The offset has therefore to be added to the calculated elevation angle. Connect a field meter to the receive IFL cable.

Set the antenna elevation, using the antenna adjust mechanism, until the inclinometer indicates the calculated elevation. Move the antenna's azimuth and elevation until carriers are displayed on the field meter. Adjust the field meter controls.

Slowly rotate the antenna for largest possible carrier amplitude. When found, tighten the antenna hardware.

1- VSAT Installation

IFL cable connections

Connect the ODU to the IDU using two IFL coaxial cables as follows:

Connect one IFL cable from the transmitter to the RF OUT port of the IDU.

Connect the second IFL cable from **the LNB to** the RF IN port of the IDU.

The cable length should not exceed the 30 meters for an RG 6 type cable.

Use RG 11 type coaxial cable for longer distances

1- VSAT Installation

Final checklist

Ensure that all the cables are connected to the correct terminals and are firmly tightened. Tie wrap cables to the antenna assembly. Leave enough extra cable at the antenna. Tie wrap the cable to the mast. Make sure that all outdoor connectors are weatherproofed after any necessary testing has been completed.

Polarization adjustment

Contact the hub operator. The final step in alignment is the Peak and Pole procedure with the satellite operations center. They will insist on correct alignment of the antenna and the polarizer in order to insure that the antenna is not interfering with adjacent satellites or with other poles on the same satellite.

1- VSAT Installation

Configuring the IDU

The IDU configuration is performed via a VT 100 terminal or a PC emulating VT 100 operation using configuration cable. Attach from the VT 100 serial port to the port 1 of the VSAT's rear panel a 25-pin RS-232 cable [You just need a typical PC-to-modem (9pin-->25pin) straight through serial RS-232 cable], set dip switch 1 ON and power on the IDU. Set the communication parameters according to VT 100 configuration as follows:

- ❖ Bits per second: 9600
- ❖ Data bits: 8
- ❖ Parity: None
- ❖ Stop bits:1
- ❖ Flow control: None

1- VSAT Installation

Configuring the IDU

Connecting Cables

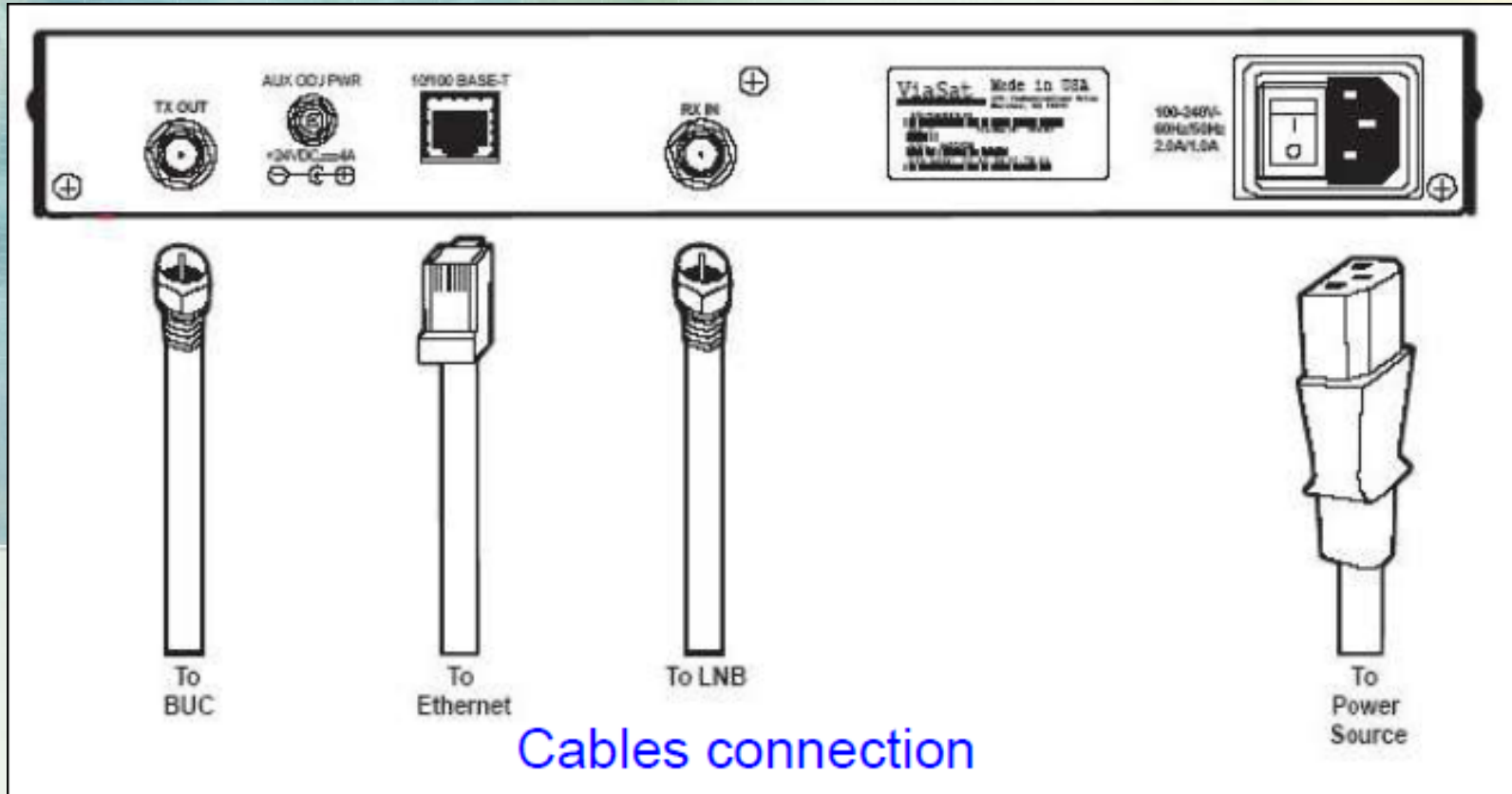

1- VSAT Installation

Configuring the IDU

The following Setting should be configured based on setting provided by the provider

- Radio frequency Tuner
- Symbol Rate
- RF Frequency
- Polarization

LAN

- The IP Address and Subnet Mask

1- VSAT Installation

Configuring the IDU

THE SATELLITE MODEM

The satellite modem provides modulation of your signal. The following parameters should be configured based on values provided by the provider

:

- Forward error correction
- Modulation techniques
- Intermediate frequency 70/140 MHz
- Data rates
- Data interfaces
- Management & control

1- VSAT Installation

Configuring the IDU

On the circuit commencement date, the duty engineers at Standard set-up a conference call between the satellite operator and the client, in order to fully activate the link. Each side sends up a test transmission at the approved frequencies. The satellite operator measures the strength of signals and requests any power adjustments that may be required.

When both sides have achieved signal lock and the signal levels are running at the correct level, the satellite operator gives approval for commencement of service. The final step is the connection of the data port at Standard to the Internet routers to enable the client to begin voice or Internet services.

1- VSAT Installation

SATELLITE DISH ASSEMBLY

The Andrew Corporation Type 243 2.4m Class III RxTx Antenna is a rugged commercial grade product suitable for the most demanding applications.

The reflector is thermoset-molded for strength and surface accuracy. Molded into the rear of the reflector is a network of support ribs which not only strengthens the antenna, but also helps to sustain the critical parabolic shape necessary for transmit performance.



1- VSAT Installation



SATELLITE DISH ASSEMBLY

The Az/El mount is constructed from heavy-gauge steel to provide a rigid support to the reflector and feed support arm. Heavy-duty lockdown bolts secure the mount to any 6.63” (168mm) O.D. mast and prevent slippage in high winds.

Hot-dip galvanizing is standard for maximum environmental protection.

- Two-piece precision offset thermosetmolded reflector.
- Fine azimuth and elevation adjustments.
- Factory pre-assembled mount.
- Galvanized feed support arm and alignment struts.
- Galvanized and stainless hardware for maximum corrosion resistance.
- Includes C-Band Circular Polarized RxTx Feed Assembly.
- Heavy-duty Class III mount for 25lb. (11kg.)
- RF electronics (LNB & BUC).

1- VSAT Installation

SATELLITE DISH ASSEMBLY



Factory pre-assembled mount.



Fine azimuth and elevation adjustments

1- VSAT Installation

SATELLITE DISH ASSEMBLY



Factory pre-assembled mount.



Fine azimuth and elevation adjustments



RF electronics (LNB & BUC).

1- VSAT Installation

CABLES AND CONNECTORS

RG11

Coaxial cables are necessary for rooftop antennas and dish antennas in order to provide crystal-clear sound and audio input. RG-11 bands typically have 75-ohm wires made of copper. Polyethylene dielectric makes sure that there is minimal loss of picture and sound while the antenna receives audio or video feeds.

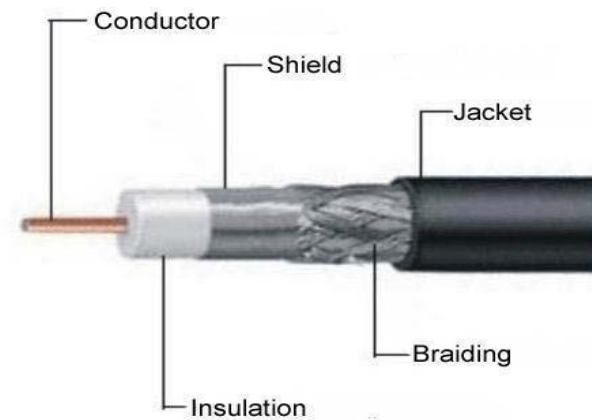

RG-11U

1- VSAT Installation

CABLES AND CONNECTORS

LMR 400

This is a high-quality braided coax cable, transmission line and radiating cable for both indoor and outdoor uses. LMR cables have RF performance comparable to traditional corrugated copper cables, but also offer flexibility, non-kinking and easy, fast connector installation that copper can't match. And when compared with other RG type braided cables, LMR cables offer far lower loss and better RF shielding.

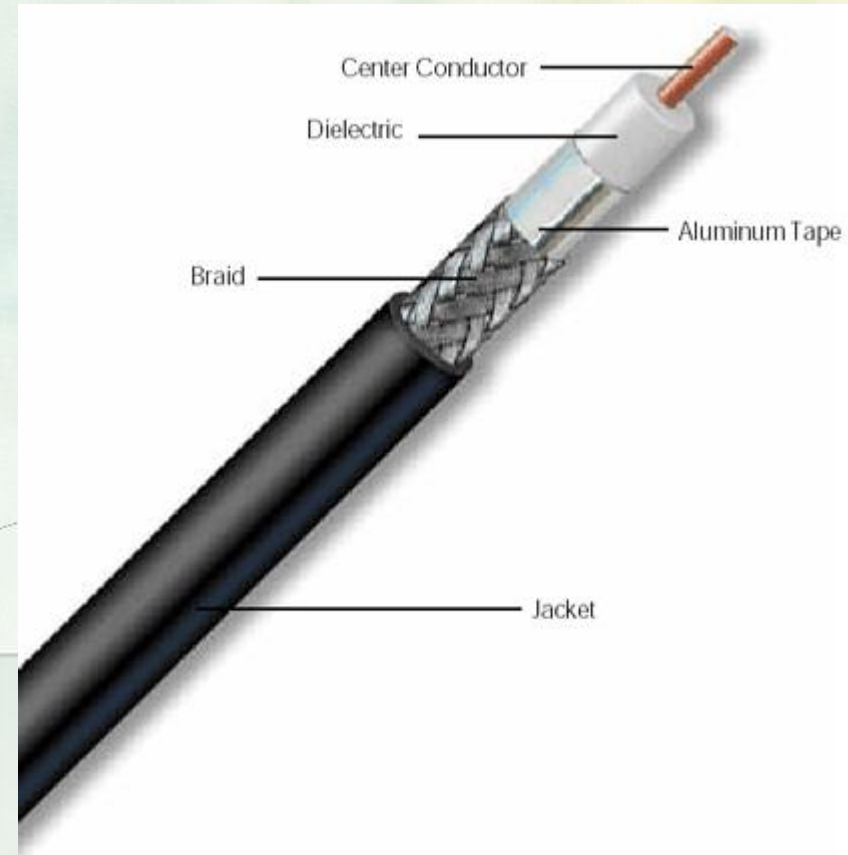

1- VSAT Installation

VSAT MOUNT



1- VSAT Installation

BUC

BUC is an abbreviation of "Block Up-Converter". It is attached direct to the transmit waveguide flange of the filter/feed assembly of a VSAT dish, used for satellite communications, The IFL cable from the indoor equipment supplies DC power, a 10 MHz frequency reference plus the actual signals to be transmitted. The signals to be transmitted are in a 575 or 300 MHz wide band, between 0.95 - 1.525 GHz and 1.1 - 1.4 GHz in the cable, which will be up-converted in the BUC to C band (5.85 - 6.425 GHz or 6.725 - 7.025 GHz, using a local oscillator mixer frequency of 4.9 or 5.625 GHz. So, Output frequency (GHz) = Input frequency (MHz) + 4.9 GHz or Output frequency (GHz) = Input frequency (MHz) + 5.625 GHz (INSAT).



1- VSAT Installation

Satellite Modems

EMR 1600

The Edge Media Router (EMR) series of satellite receivers and routers are versatile and powerful networking platforms that receive and manage content at the network edge. The EMR series provides a complete satellite Internet solution. The Micro-EMR-1600 is a compact satellite receiver and media router for cost-effective satellite connectivity to the SOHO environment.



1- VSAT Installation

Satellite Modems

DMD 20 Satellite Modem

Radyne's DMD20 Satellite Modem breaks new ground in flexibility, operation and cost. With standards including IDR, IBS and DVB, and covering data rates up to 20 Mbps, this 1RU duplex modem covers virtually all your Satellite IP, Telecom, Video and Internet applications.



1- VSAT Installation

Routers

Cisco router 1841

The Cisco 1841 Integrated Services Router provides the following support:

- Wire-speed performance for concurrent services at T1/E1 WAN rates
- Enhanced investment protection through increased performance and modularity
- Enhanced investment protection through increased modularity
- Increased density through High-Speed WAN Interface Card Slots (two)
- Support for over 90 existing and new modules
- Support for majority of existing WICs, VWICs, and VICs (data mode only)
- Two Integrated 10/100 Fast Ethernet ports

1- VSAT Installation

Routers

Cisco router 1841

Security

- o On-board encryption
- o Support of up to 800 VPN tunnels with the AIM Module
- o Antivirus defense support through Network Admission Control (NAC)
- o Intrusion Prevention as well as stateful Cisco IOS Firewall support and manymore essential security features



1- VSAT Installation

Firewall

Cisco ASA 5505 Firewall

Cisco ASA 5500 Series adaptive security appliances are purpose-built solutions that combine best-of-breed security and VPN services with the innovative Cisco Adaptive Identification and Mitigation (AIM) architecture. Designed as a core component of the Cisco Self-Defending Network, the Cisco ASA 5500 Series provides proactive threat defense that stops attacks before they spread through the network, controls network activity and application.



1- VSAT Installation

IDIRECT ROUTER

The Idirect 3000 Series Satellite Router is a star-topology remote satellite router designed as an easy-to-deploy solution integrating a satellite modem, IP router, TCP acceleration and advanced QoS and prioritization capabilities. The 3000 Series Satellite Routers support IP data rates up to 18 Mbps downstream and up to 5 Mbps upstream. The routers also come as a narrow-band model capable of delivering the same downstream IP data rates, but limited on the upstream to 200 kbps.

This replaces the use EMR 1600 and Satellite Modem



1- VSAT Installation

Typical settings

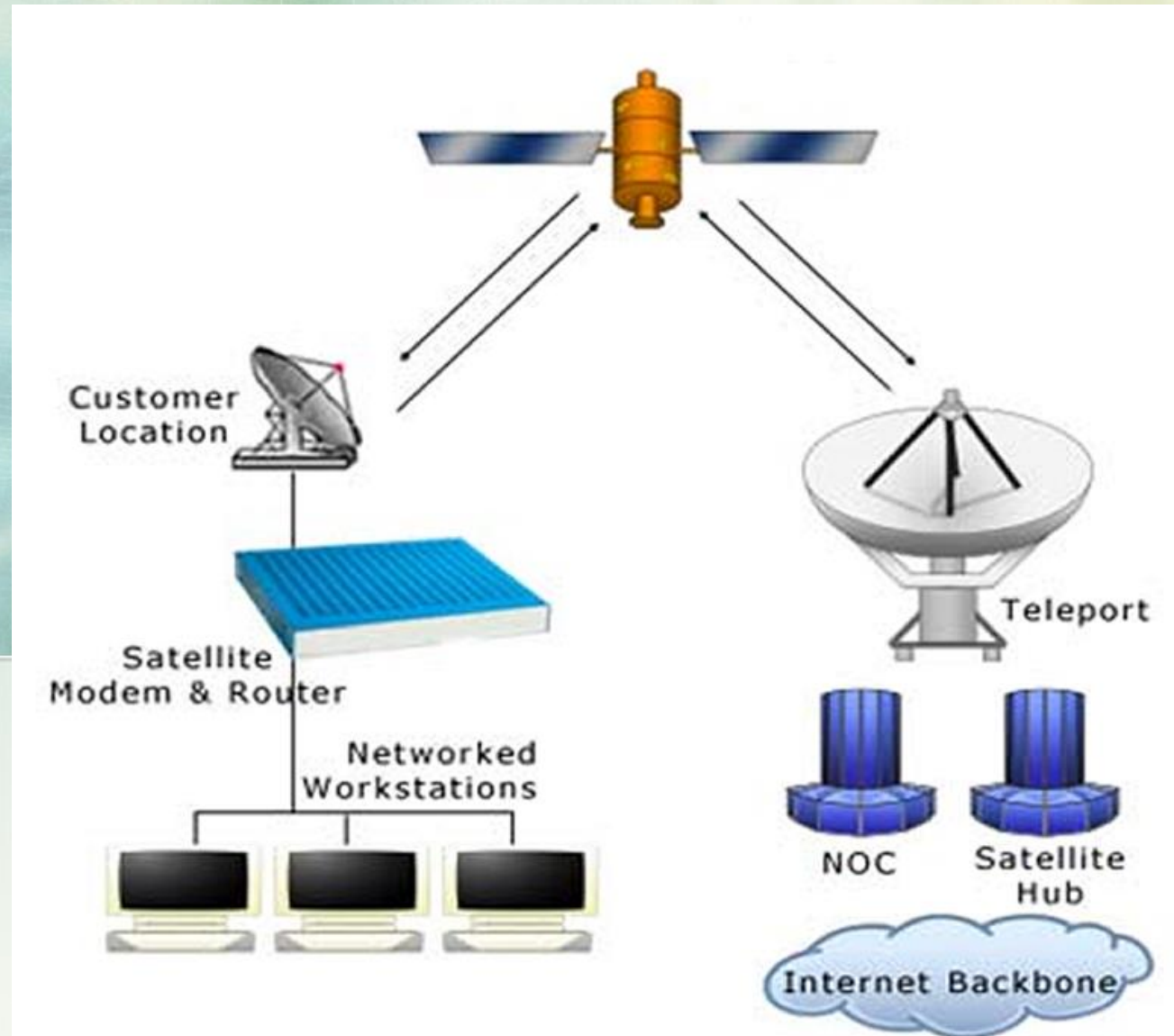

1- VSAT Installation

Satellite pointing

Before you start radiating power towards the satellite

- Make sure you have a site specific Antenna and radio configuration (ARC) sheet. This ARC sheet which is a part of the Field installation documentation is the full responsibility of the satellite service provider.
- Contact the satellite control center at least 24 hours prior to the actual antenna lineup to schedule your action. Inform the satellite control center about the site-specific details as name of the customer and the site code (or carrier ID). Confirm transmit and receive frequencies.
- Build the antenna according to the “Antenna assembly procedure”,
- Point the antenna to the correct satellite
- Set azimuth and elevation
- Allow the radio to warm up for at least 15 minutes before any transmission
- Call the satellite control center and act in accordance with their instructions

1- VSAT Installation

Satellite pointing

The goal is to achieve the best possible elevation, azimuth and cross-pol isolation on receive. Elevation, azimuth and polarization offset are normally given in the Antenna and Radio configuration (ARC) sheet. In the event you do not have the sheet on site while doing an installation you can easily calculate some of the necessary parameters.

With the Latitude, Longitude and Elevation of the site and also satellite position, you can calculate the Azimuth and Elevation of the antenna.

Useful software can be found on the internet.

The elevation and azimuth values for the antenna are given in the “antenna and radio configurations” sheet which is a part of the field installation documentation. Indispensable for setting the elevation is an inclinometer.

1- VSAT Installation

Satellite pointing

Elevation

- Place the inclinometer on the metal frame at the rear of the antenna
- Adjust the elevation until the inclinometer indicates the correct value. Be advised that if you are off the correct elevation you will never find the satellite. Bigger apertures require more accuracy.

Note: The antenna and radio configuration sheet gives you're the true elevation (or the elevation for a prime focus antenna). Many companies prefer the use of offset antennas. To achieve the correct inclinometer readout simply subtract the antenna offset form the elevation given in the Field installation documentation.

1- VSAT Installation

Satellite pointing

Elevation

Antenna Offset Examples

Andrew 0.96m	1 piece 0.875f/d	15.40°
Andrew 1.2m	1 piece 0.875f/d	16.97°
Andrew 1.8m	1 piece 0.6f/d	22.62°
Prodelin 1.8m	1 piece 0.6f/d	22.30°
Andrew 2.4 m	2 piece 0.6f/d	22.62°
Prodelin 2.4m	4 piece 0.8f/d	17.35°
Prodelin 3.8m	4 piece 0.8f/d	22.62°

1- VSAT Installation

Satellite pointing

Azimuth

Azimuth can be measured using a compass. However, a compass doesn't work well near steel obstructions and frameworks commonly found in buildings. Strong magnetic fields dramatically affect compass reading as well. This is called deviation. Besides a compass always points at the magnetic north. The given azimuth in the antenna and radio configuration sheet always refers to the geographic north. This means that you always have to deal with a difference between the magnetic north and the geographic north.

This is called the variation and depends very much on where you are on earth. To find the true azimuth you first must subtract or add the variation to your compass reading.

1- VSAT Installation

Satellite pointing

Elevation _____

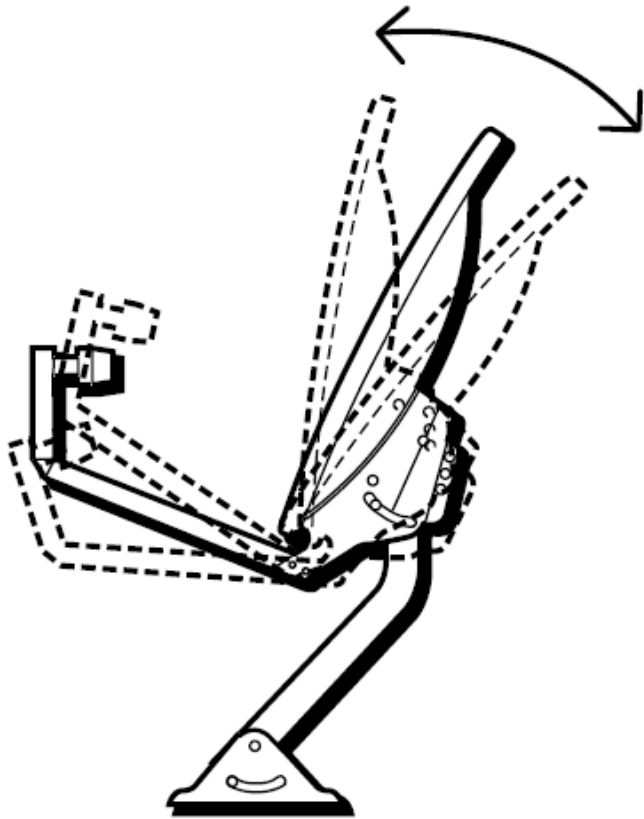

Elevation is the up/down angle that the dish is pointed

Azimuth _____

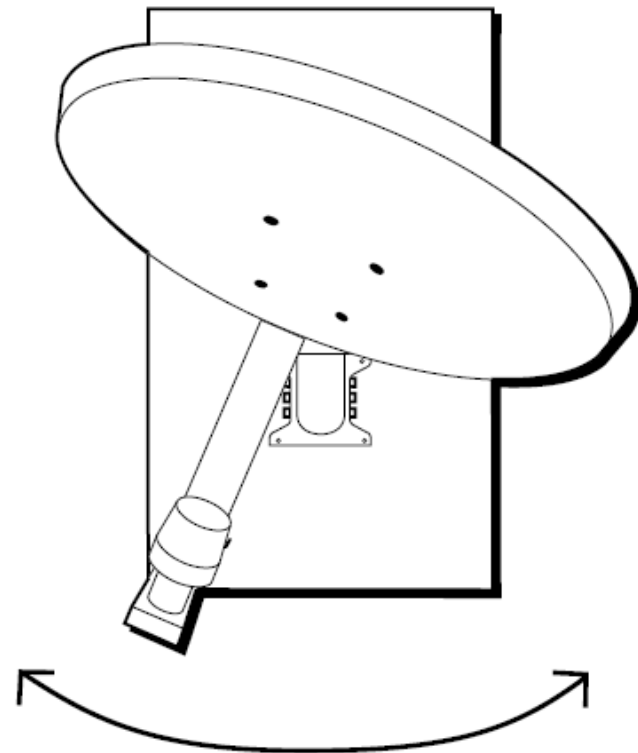

Azimuth is side to side direction that the dish is pointed

1- VSAT Installation



Satellite pointing

Connect the spectrum analyzer

- Read the compass at ground level. Stay away from motors and large steel constructions.
- Identify a landmark in the assigned azimuth pointing direction and refer to the landmark when pointing the antenna.
- Since the LNB is powered with DC over coax it is not possible to connect the spectrum analyzer straight to the LNB. Connect the spectrum analyzer to the monitor output of the receiver. If your receiver does not support a monitor output use a sufficient inserter (ordinary splitters can't be used). Be very careful not to feed the spectrum analyzer with DC power. In most of the cases you will blow up the spectrum analyzer input immediately.
- Program the spectrum analyzer center frequency for one of the pilot carriers on the satellite. Use a wide span and maximum sensitivity.

1- VSAT Installation



Satellite pointing

Connect the spectrum analyzer

T11 Pilot Frequency [Khz] / Polarization	Type of LNB
12 528 000 / V	Euro High Band
11 656 260 / V	Euro Low Band
11 728 000 / H	Noram

LNB BAND	LNB Input Frequency [GHz]	LNB Local Oscillator [GHz]	LNB Output Frequency [MHz]	LNB Bandwidth [MHz]	T11 Pilot After down Conversion [MHz]
Noram	11.70 – 12.20	10.75	950 – 1450	500	978
Euro Low	10.95 – 11.70	10.00	950 – 1700	750	1656.26
Euro High	12.25 – 12.75	11.30	950 - 1450	500	1228

1- VSAT Installation



Satellite pointing

- Move the antenna slowly (not faster than two degrees per second) from the left to the right. Move the antenna while looking at the spectrum analyzer.
- If you “hit” the satellite a bunch of signals will appear on the spectrum analyzer. When using a DRO LNB (a LNB with a free running local oscillator) and you bring your spectrum analyzer back to a very narrow span you will see that the pilot carrier is not stable. This is normal.
- Toping the level of the pilot roughly. The C/N should be better than 20 dB
- Topping the level of the pilot. Go for the best result. Do this by fine-tuning azimuth and elevation.

1- VSAT Installation



Satellite pointing

- Secure azimuth and elevation
- Find a minimum for the pilot level. Do these by adjusting the polarizer (position of the feed) only, in most of the cases you will find two notches. Choose the one, which gives you the best result (the difference between minimum and maximum should be at least 35 dB). Mark this position on the donut and move the feed exactly 90°. The level of your pilot carrier is topped now and you are receiving exactly the polarization in which the pilot carrier comes down.
- If the downlink polarization given in the ARC sheet is opposite of the pilot polarization then set the polarizer in its correct position (90° swing)

1- VSAT Installation



Basic Configuration

THE EMR 1600

CONFIGURATION PARAMETERS

The EMR 1600 configuration is performed via internally provided web based configuration system via a VT 100 terminal or a PC emulating VT 100 operation using configuration cable.

The following Setting should be configured based on setting provided by the provider

Radio frequency Tuner

- Symbol Rate
- RF Frequency
- Polarization

LAN

- The IP Address and Subnet Mask

1- VSAT Installation



Basic Configuration

THE SATELLITE MODEM

The satellite modem provides modulation of your signal. The following parameters should be configured based on values provided by the provider

- Forward error correction
- Modulation techniques
- Intermediate frequency 70/140 MHz
- Data rates
- Data interfaces
- Management & control

THE CISCO ROUTER

The router basic configuration has to be provided by the ISP

2- Maintenance

PREVENTIVE MAINTENANCE

Good maintenance, knowledge of the site and well maintained records are the basis for avoiding any unexpected faults. However, an unexpected failure may cause outages and emergency repairs may be necessary by the on-shift technician or VSAT technician.

To meet the guarantee, and to keep the link functioning, you need to have a regularly scheduled antenna inspection and maintenance program.

2- Maintenance

PREVENTIVE MAINTENANCE

The lack of a well implemented preventive maintenance program could trigger a wave of problems. An electrical or physical failure could lead to a complete antenna failure, causing downtime or even loss of contract. It is known that 50-70 percent of all outages are caused by:

1. Equipment incl. the antenna error
2. Human error
3. Lack of experience on equipment and test equipment
4. Improper or mal-function test equipment.

This means that most failures can be avoided and outages

Maintaining an earth station antenna is much less costly than to repairing one that has failed.

2- Maintenance

PREVENTIVE MAINTENANCE

The maintenance program should include maintenance to the following items:

- Inspect the total appearance of the equipment including radio, LNC, feed horn and de-icing systems
- Inspect the antenna mount hardware
- Inspect the ground connections
- Inspect the power equipment and facilities
- Inspect the IF equipment and terminal equipment (including modems, mux and M&C equipment)
- Inspect the enclosures
- Inspect the cables and connections
- Inspect areas exposed to the weather to insure they are adequately waterproofed
- Evaluate antenna's overall performance

2- Maintenance

PREVENTIVE MAINTENANCE

Reliable and effective maintenance depends upon good test equipment which is regularly calibrated in accordance with manufacturer's recommendations. In the maintenance we should :

- Check appearance
- Check Mount Hardware
- Verify ground connections
- Inspect enclosures
- Maintain cables
- Maintain equipment
- Antennas move
- Monitor & Control
- Radio equipment and rack fan

2- Maintenance

Maintenance actions schedule

Generally the maintenance procedure takes from one hour to half a day, depending on the environmental conditions under which the antenna operates.

All the maintenance activities must not only be scheduled in advance with the customer but also coordinated with the different support organizations in the same way installation activities are scheduled.

Reliable and effective maintenance depends upon good test equipment which is regularly calibrated in accordance with manufacturer's recommendations

2- Maintenance

Maintenance actions schedule

The lack of a well implemented preventive maintenance program could trigger a wave of problems. An electrical or physical failure could lead to a complete antenna failure, causing downtime or even loss of contract.

A dated log (started from day one) with photographs should be prepared when the antenna (and the other parts of the site) are installed. Entries into the log should be made during each inspection so a complete record of the entire antenna system and its condition is available.

Maintenance logs should be stored with the equipment or within the equipment rack.

2- Maintenance

Maintenance process

Check appearance

Inspect all painted and galvanized surfaces of the antenna and its mounting structures at least once a year; however never paint the coated Prodelin reflector! Note that most of the antenna reflectors do not need much maintenance however a visually pleasing installation helps avoid community opposition to its presence. Local requirements vary among countries but appearance is a factor.

If the main reflectors are made of painted steel, be sure to follow the manufacturer's instructions for preparation of the surface and for paint specifications. Remember that the wrong paint can affect your signal. Darker colors on the reflector's surface absorb sunlight; the resulting higher noise temperatures could cause signal distortion. Paint with too much lead can cause signal loss through attenuation or scattering. Today most of the reflectors are fiberglass with imbedded mesh. Repainting therefore is not necessary.

2- Maintenance

Maintenance process

Check mount hardware

Not surprisingly, corrosion is the enemy of the nuts, bolts and other fasteners used to assemble the antenna mount. Therefore, it is necessary to inspect the mount hardware, tighten loose bolts and replace missing or badly corroded parts. If loose bolts are found, and if they affect the antenna pointing, contact the satellite operations center and notify them that the antenna needs to be re-pointed.

Repair any damage, even if it is minor.

2- Maintenance

Maintenance process

Verify ground connections

The antenna mount and RF unit should be grounded against possible lightning strikes. The grounding for both mechanical and non-mechanical connection must be verified - a ground loop impedance test unit does very well. After checking mechanical ground connections, replace rusted or corroded hardware to prevent a build-up of resistance.

Grounding system performance check means that the original grounding installation must be periodically tested to determine whether resistance is remaining constant or increasing.

2- Maintenance

Maintenance process

Inspect enclosures

Vermin (bees and spider webs, birds, etc) can do unbelievable and costly damages if left unchecked. If equipment is housed in an antenna enclosure at the rear of the reflector, inspect the enclosure for water retention or infestation by insects or rodents. Repair and seal any suspicious openings.

2- Maintenance

Maintenance process

Maintain cables

Inspect and verify connector weather sealing and all cable tiles. The inter facility link (IFL) cables carry intermediate frequency and monitor and control signals between the roof and the equipment room. If on inspection and you find or suspect any VSWR and/or insertion loss (IF Cable only), check to see whether any cables need to be replaced or repaired. (Are they water proof?) With a simple “home garden and kitchen” multimeter, the cables and the connectors check the conductivity and continuity of the cables. Also ensure that the cables support and routing are consistent with the requirements. Stainless steel cable hangers or clamps are preferable to plastic cable ties for supporting the cable. If plastic ties are used, use only black nylon ultraviolet resistant ones. White or clear ties become brittle and break with prolonged exposure to sunlight.

2- Maintenance

Maintenance process

Antenna moves

Whenever the antenna has to be moved or the IFL cable is disconnected, the antenna must be taken out of service.

Use this opportunity to inspect the antenna

2- Maintenance

Maintenance process

Monitor and control (M&C)

Monitoring and control is an activity of both corrective and preventive maintenance. Regular measuring and recording of essential parameters will help note and identify potential faults.

Verify that the NOC can access the site and check for current alarm conditions on all equipment. Also verify that M&C to radio is connected and functional and that telephone access is available on the roof via the M&C line

2- Maintenance

Maintenance process

Radio, equipment and rack fan

Check to ensure the fan in the radio is operating properly. If not, repair as soon as possible because radios may fail within a few hours if not properly cooled. Check that all filters, if present, are clear and free from dust build up and inspect chassis air passage openings

2- Maintenance Troubleshooting

WHAT TO DO WHEN THINGS GO WRONG

Obviously, if you need help, the NOC is available. But before you call, please take a bit of time to track down and fix your problem yourself. Ensure you are up to date with your preventive maintenance.

It goes without saying that rebooting computers and checking cables is the most common fix of any Internet Service Provider. Take your time in hunting down a problem and make sure that it's not hardware related.

2- Maintenance Troubleshooting

WHAT TO DO WHEN THINGS GO WRONG

And don't rule out hardware errors. A great way to test this is to use an alternate bypass such as switching network cables, coax cables, or a different computer when all else fails.

If you are having signal related problems... try to locate the error by checking your dish.

The idea is not to panic and that most problems are normally an easy fix... once the problem is located.

If all does not get well, call the network operations centre.

2- Maintenance

Service Level agreement

Companies operating VSATs , often delegate maintenance to specialized companies that will be responsible of the maintenance of the VSAT.

A contract is then signed between the two companies where an Service Level Agreement (SLA) is stated.

The SLA must be complete to avoid misunderstanding between the two parties and permit an excellent operation of the VSAT.

2- Maintenance

Service Level agreement

SLA Definition

An SLA is a formally negotiated agreement between two parties. It is a contract that exists between customers and their service provider, client or between service providers. It records the common understanding about services, priorities, responsibilities, guarantee, and such – collectively, the *level of service*. For example, it may specify the levels of availability, serviceability, performance, operation, or other attributes of the service like billing and even penalties in the case of violation of the SLA.

2- Maintenance Service Level agreement

SLA Content

The SLA may include :

- Bandwidth availability
- Response times for problem resolution
- Escalation procedures
- Links performance
- Penalties in case of violation,...

2- Maintenance

Escalation procedure

Escalation procedure

The process set up to define the steps taken when service levels don't meet upon standards. This may involve determining fault for missed measures, reporting, problem resolution within a specified time and -- when the problem still isn't resolved -- executive intervention on both the client and service provider sides.

2- Maintenance Spare Management

Spare Management

For ease and fast maintenance it is necessary for customer to have on site some spare parts. The following hardware can sometimes be faulty, and so need some spare parts to be kept for possible replacement:

- BUC
- LNB
- Modem
- Feed horn

End of Day 4 course

VSAT Installation and Maintenance