



ITU/ITSO Workshop on Satellite Communications, AFRALTI, Nairobi Kenya, 17-21, July, 2017

VSAT Installation and Maintenance

Presenter: E. Kasule Musisi
ITSO Consultant
Email: e.musisi@kiyindi-electric.com
Cell: +256 772 783 784



Economics of VSATs Installations

- Satellite Cost 100s of millions of dollars
- Hub stations cost 100s of thousands of dollar
- In a “hubbed” configuration 100s or even 1000s of VSAT may need to be installed in a network
- VSATs are “ End-User terminals”- the equivalent the Mobile phone handset in a GSM network
- For the satellite business to make sense, VSATs should be
 - low cost and
 - simple to install “DIY”
- Remember the **Link Budget**? A bad installation can cost your company a customer!
- Unlike the Link Budget, there is no room for “back and forth” - most of the time!

VSAT Installation is part of a process

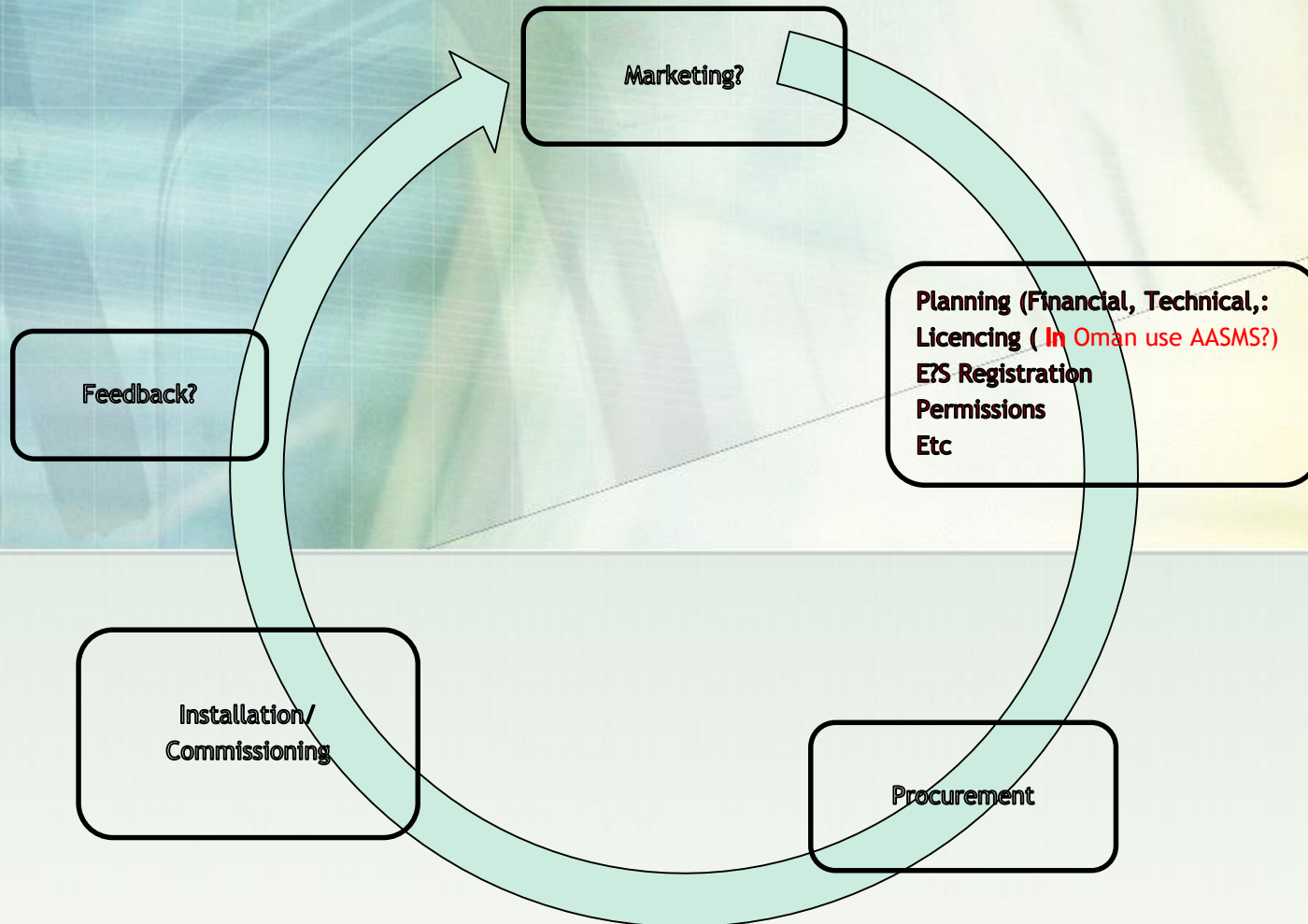



Planning and Preparations

- VSAT are usually installed in remote or difficult to reach areas with poor communications. Quite often an emergency situation may exist. Good planning and preparation is therefore essential to save time and money
- The satellite are very many and closely spaced up there. Finding the one you want within the time available is a “do or die” affair. Be prepared both **logistics-wise** and **psychologically**. **Checklist:**

The right tools?

The planning data e.g. Configuration parameters

Hardware List?

Damage?

Permissions?

Installation Materials?



Authorizations and Permissions

May be required from:

- Regulator
- Management Approval (e.g. for elevation of $<10^\circ$)
- Landlord
- Urban Planning Authority
- Hub Operator
- Satellite Service Provider



Landlord Permissions

- If penetrating the roof is allowed, secure the pole to the roof with penetrating large bolts.
- In case penetration of the roof is not possible, a non-penetrating mount should be used.

Installation

- Site Survey
- Tools (Basic Tools, Specialised tools)
- Role of Network Operations Center (NOC)
- Dish Assembly
- Mounting
- ODU Assembly
- IDU Configuration
- Satellite elevation and azimuth
- Antenna Pointing
- Polarisation Adjustment

Maintenance

- Preventive Maintenance (Checklist)
- Typical causes of outages
- Corrective Maintenance
- Troubleshooting
- Escalation Procedures
- Spares (List)
- Service Level Agreements (Content)

Site Survey_{1/4}

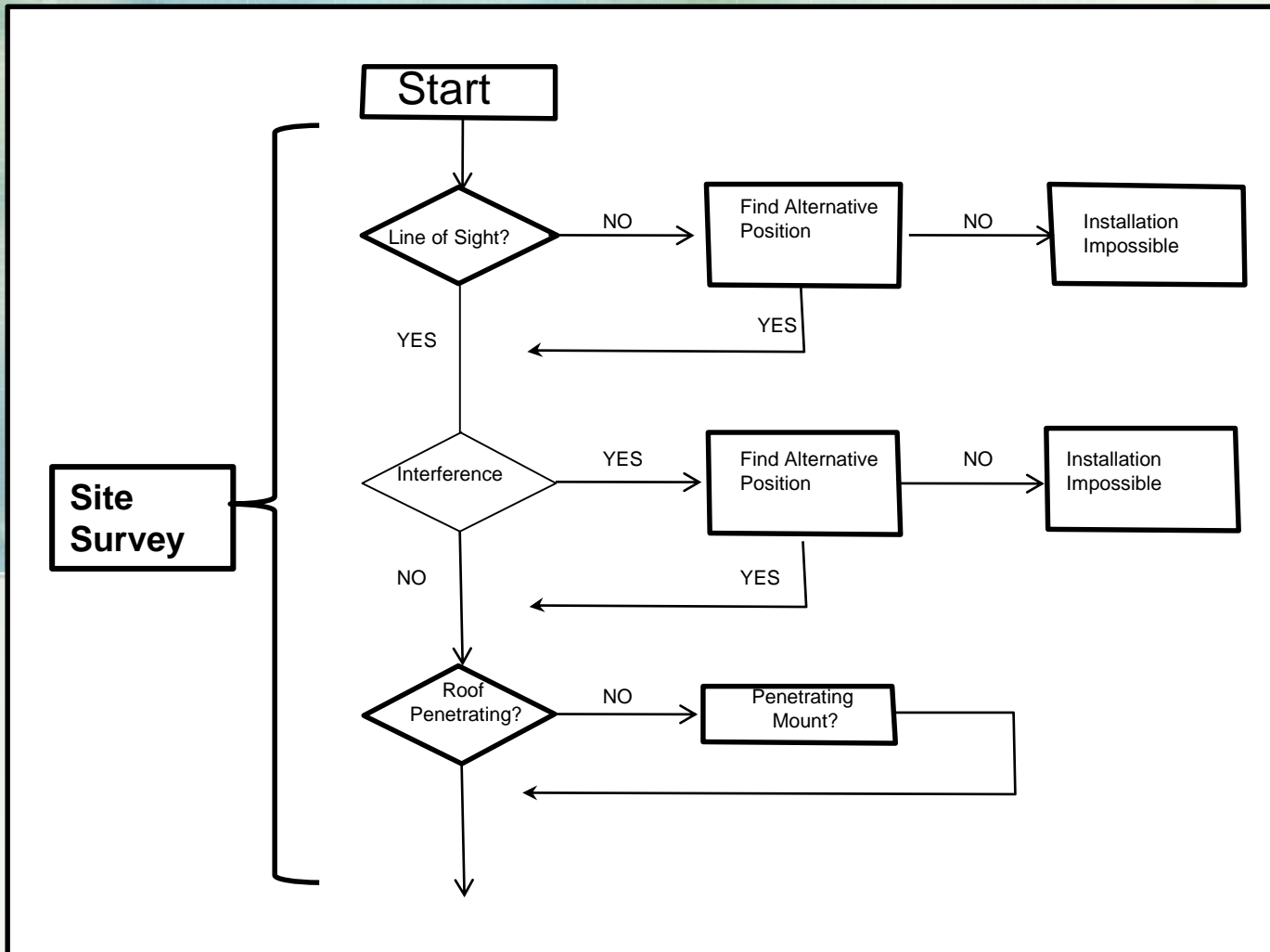

Site Survey_{2/4}

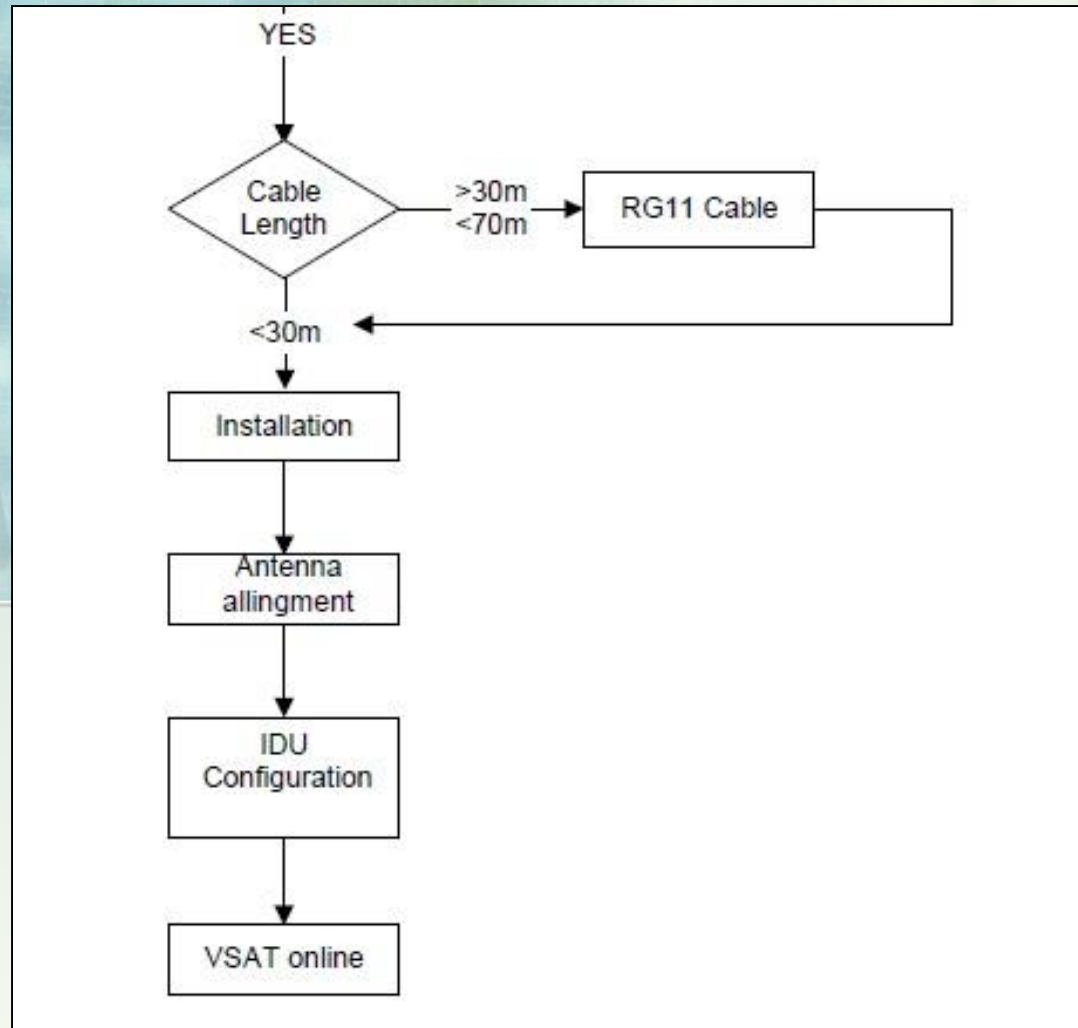



Site Survey_{3/4}

- Absence of high-rise buildings, trees etc, which may block the Line of Sight (LOS).
 - Absence of interference
 - Existence of AC power (required during installation)
 - Existence of a clear, unobstructed line of sight to the designated satellite
 - Note the longitude and latitude of site (or confirm LBA assumption)
-
- Existence of a LAN network near the IDU.
 - Estimation of the maximum cable length.
 - Free access to the roof of the building (if roof top installation)

Site Survey_{4/4}

Absence of high-rise buildings, trees etc, which may block the signal path.
If the elevation is between 30° and 60° Imagine an arc ranging from 30 to 60 degrees above the horizon.

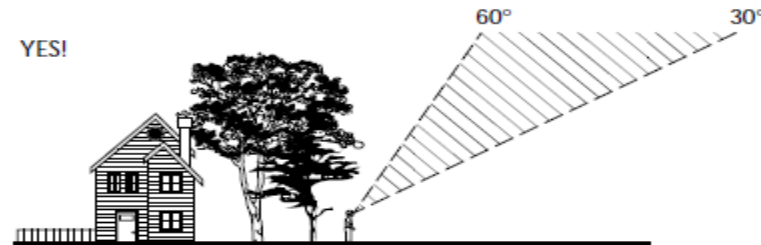

Tools (Basic Tools, Specialised tools)

- **Basic Tools: compass, inclinometer**
- **Specialised tools/test gear -spectrum analyser**



Role of Network Operations Center (NOC)

In “hubbed” or “networked” applications the role of the Hub Station (which also typically doubles as the NOC) is high. The trend is to reduce time and expertise in the field. The aim is to automate and/or remote control the installation activities.

Dish Assembly



A properly assembled sat dish.



Dish Assembly



Factory pre-assembled mount.



Fine azimuth and elevation adjustments

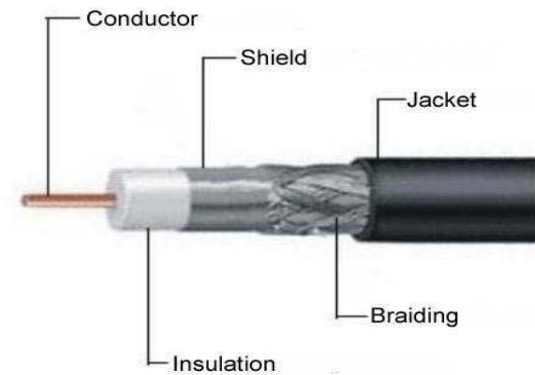

RG-11U

Feed, BUC, LNB, RF Cables

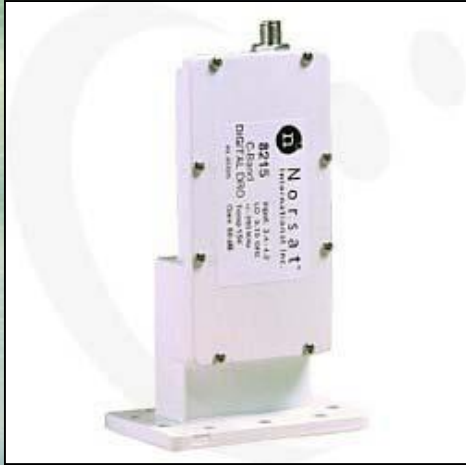

LNB



Feed Assembly

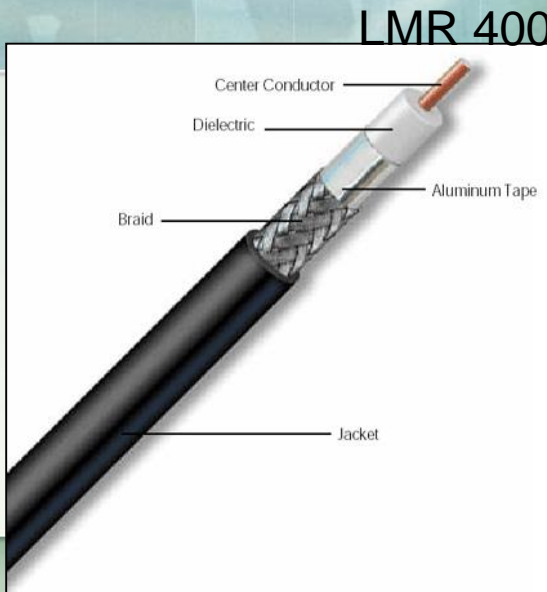

LMR 400



BUC

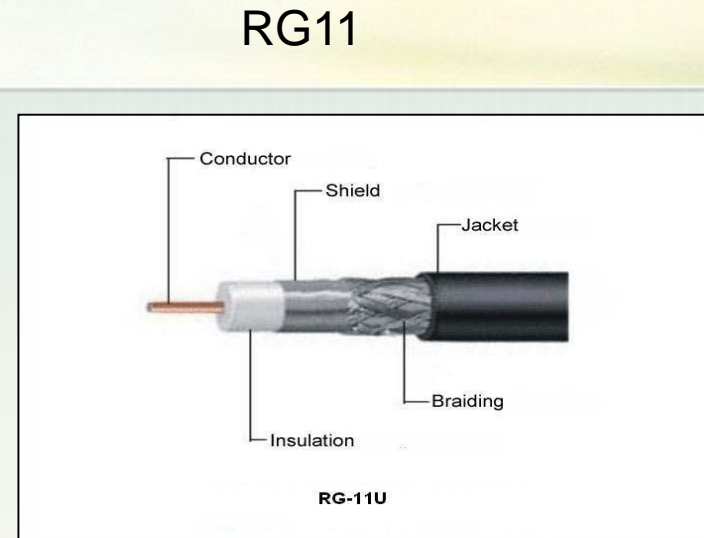

RG11

VSAT MOUNT



VSAT antenna pointing 1/3

Elevation _____

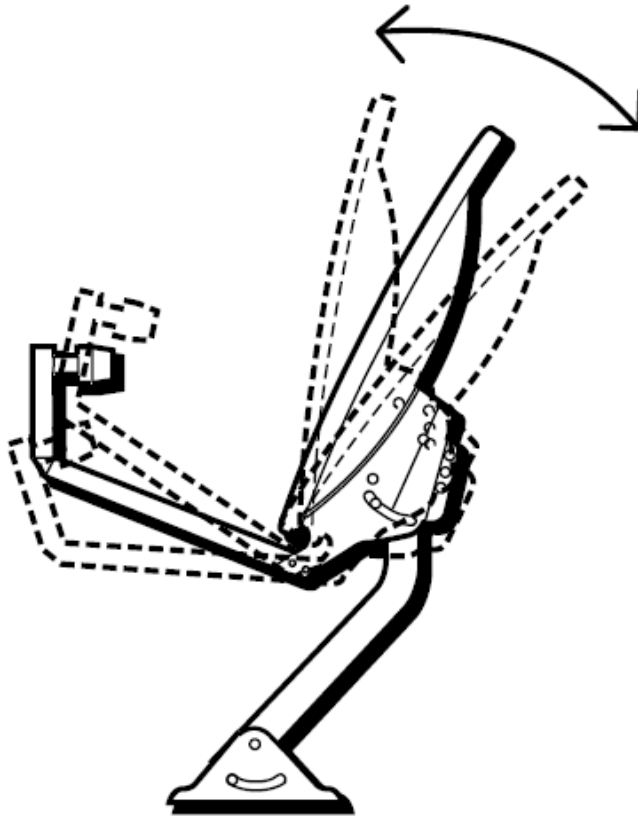

Elevation is the up/down angle that the dish is pointed

Azimuth _____

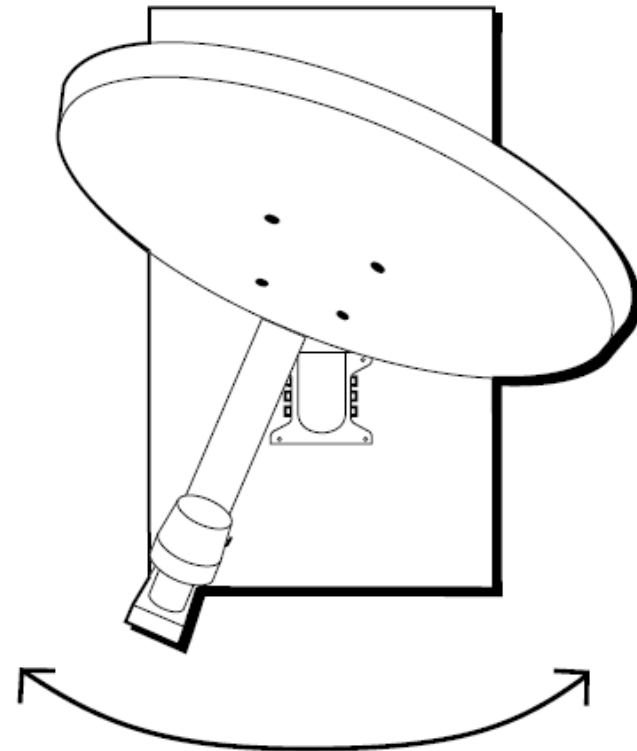

Azimuth is side to side direction that the dish is pointed

VSAT antenna pointing ^{2/3}

Antenna Offset Examples

Andrew 0.96m	1 piece 0.875f/d	15.40°
Andrew 1.2m	1 piece 0.875f/d	16.97°
Andrew 1.8m	1 piece 0.6f/d	22.62°
Prodelin 1.8m	1 piece 0.6f/d	22.30°
Andrew 2.4 m	2 piece 0.6f/d	22.62°
Prodelin 2.4m	4 piece 0.8f/d	17.35°
Prodelin 3.8m	4 piece 0.8f/d	22.62°



VSAT antenna pointing ^{3/3}

Using a spectrum analyzer for pointing

- **Note:**

Since the LNB is powered with DC over coax it is not possible to connect the spectrum analyzer straight to the LNB. You could blow up the spectrum analyzer input!



Maintenance ^{1/4}

Good maintenance, knowledge of the site and well maintained records are the basis for avoiding any unexpected faults. However, an unexpected failure may cause outages and emergency repairs may be necessary by the on-shift technician or VSAT technician.

To meet the guarantee, and to keep the link functioning, you need to have a regularly scheduled antenna inspection and maintenance program.



Maintenance 2/4

It is known that 50-70 percent of all outages are caused by:

- Equipment incl. the antenna error
- Human error
- Lack of experience on equipment and test equipment
- Improper or mal-function test equipment.

This means that most failures can be avoided and outages

Maintaining an earth station antenna is much less costly than to repairing one that has failed.



Maintenance ^{3/4}

Preventive Maintenance Check List

Appearance

Hardware tightening

Earthing (or grounding) connections

Outdoor enclosures inspection

Antenna pointing

Equipment fans



Maintenance 4/4

- Companies operating VSATs , often delegate maintenance to specialized companies that will be responsible of the maintenance of the VSAT.
- A contract is then signed between the two companies where an Service Level Agreement (SLA) is stated.
- The SLA must be complete to avoid misunderstanding between the two parties and permit an excellent operation of the VSAT.

Maintenance Outsourcing

SLA Content

The SLA may include :

- Bandwidth availability
- Response times for problem resolution
- Escalation procedures
- Links performance
- Penalties in case of violation,...



Troubleshooting

Escalation procedure

The process set up to define the steps taken when service levels don't meet upon standards. This may involve determining fault for missed measures, reporting, problem resolution within a specified time and -- when the problem still isn't resolved -- executive intervention on both the client and service provider sides.

Spares Management

Due to high integration a VSAT just a handful of parts that can fail. The following hardware can sometimes be faulty, and so need some spare parts to be kept for possible replacement:

- BUC
- LNB
- Modem
- Feed horn



End

Thank You!

Questions?